

HULL BUILDING BOARD

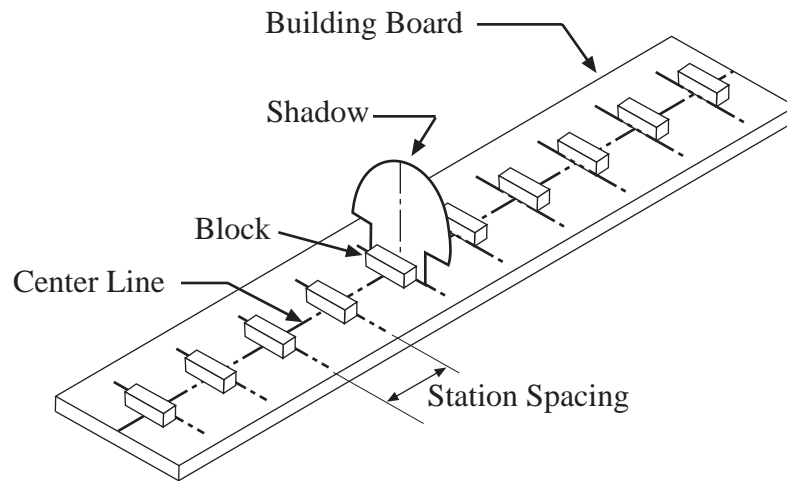

The board has to be “warp-free”. It can be plywood or particle board shelving material. Particle board is a little more difficult to cut and drive nails into than plywood. Size of the board is about 5/8" x 12" x 48". If you want to keep the board clean, cover it with shelf paper.

Draw a center line on the length of the board. Draw station spacing lines at right angles to the center line. Make sure the spacing is correct for the hull design. Lightly nail small wood blocks (about 3/4" x 3/4" x 2") to board at station spacing lines. Note that blocks are placed in front of station lines 1 thru 5 and behind sta-

tion lines 6 thru 10. Do not drive nails “home”. They will be removed later.

Trace shadows (frames or formers) on 1/8" thick “doorskin” plywood or untempered hardboard. These shadows will be discarded later. Be sure you have a center line on each shadow. Cut out shadows, and sand any rough spots. Glue shadows to blocks on building board. Use 5 Minute Epoxy or hot glue. Be sure center line on the shadows lines up with center line on building board.

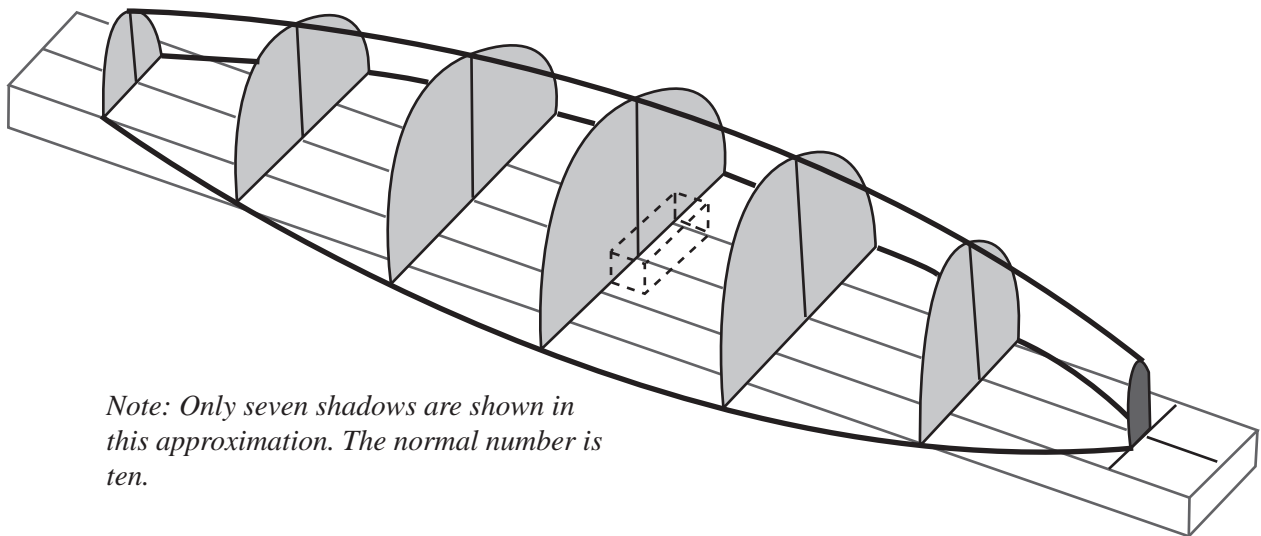

Note: Only seven shadows are shown in this approximation. The normal number is ten.

BALSA STRIPPER

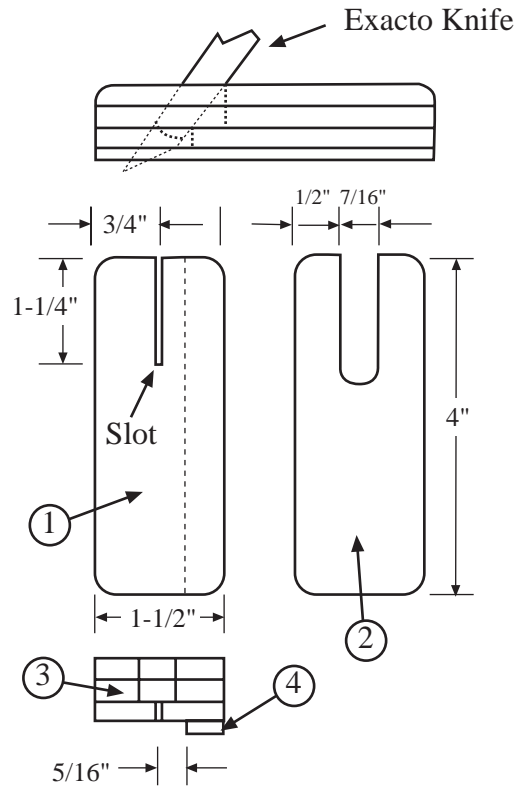

1. 1/4" thick plywood (make one). Notice slot is cut at slight angle.
2. 1/4" thick plywood make two.
3. Glue 1 and 2 together. Use 5- minute epoxy or Zap.
4. Glue 1/8" x 7/16" x 4" pine fence (strip) in place as shown. This fence determines the width of balsa strip to be cut. Change this dimension to suit your strip width.

Slightly round the top edges.

Lay balsa sheet on flat workboard or similar cutting surface. Grasp stripper between thumb and last three fingers of right hand.

Insert X-ACTO (or similar) knife in slot. Hold in place with right index finger. Place fence against edge of balsa sheet. Draw stripper slowly along edge keeping fence pressed firmly against edge. Make two or three passes if necessary.

SOUTHPAWS TAKE NOTICE !!!

A left handed version can be made by reversing the plan.

EASY WAY OUT

You can buy one from the hobby shop for a couple of bucks.

HOW TO STRETCH BALSAWOOD

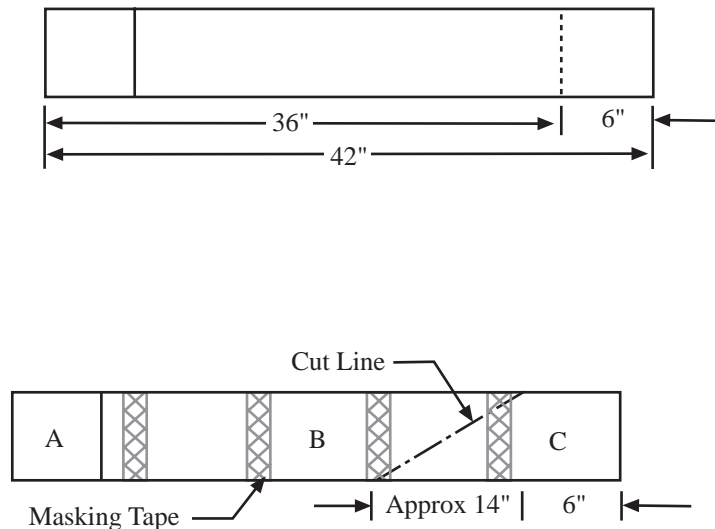

You want to build a model boat that is 40" long and the only sheet balsa available is 36" long. What do you do? You “scarf” the balsa sheets, that’s what you do.

Place two 1/8" X 4" X 36" (or whatever thickness and width you are using) balsa sheets together with the top sheet extending 6" beyond the bottom sheet (Fig. 1). Tape sheets together using masking tape. Draw a light pencil line as shown by dotted line (Fig.2). Cut both sheets along this line using a jig saw or band saw. An X-ACTO type knife can also be used. Be sure to keep the knife blade perpendicular to balsa sheets.

Place a sheet of wax paper or other plastic wrap (kitchen items) on a flat surface. Place section A and

C together on the wax paper as shown in Fig. 2. Use masking tape or weights to hold sheets in position. Run a bead of CA glue (Zap, Hot Stuff, ect., “gap filling” type) along seam. White or carpenter’s glue may also be used but takes longer to set.

Make a second sheet by reversing section B and proceeding as before. You will have 3 pieces of scrap material left over. Repeat this procedure until you have enough sheets to plank your hull.

Strip sheets into planks of the desired width with your balsa stripper.

Be sure to “stagger” the joints when planking. Plank carefully and the joints will be barely noticeable.

PLANKING THE HULL

To build a straight hull you must have a sturdy jig to hold the station formers in alignment with the keel center line, they also must be perpendicular to the center line both vertically and horizontally.

Draw or trace the station former out- lines on paper, cut them out and glue them to the former material with rubber cement. You can use 1/8" thick door skin plywood (or any other suitable material) for former material. Cut the formers out and sand the edges to conform to the paper templates.

Cover the edges of the formers with masking tape, where the hull planking will make contact. This helps prevent the glue from sticking to the formers. Now attach the formers to the building jig. Make sure station spacing and former alignment is correct.

Before we start building lets talk about materials used

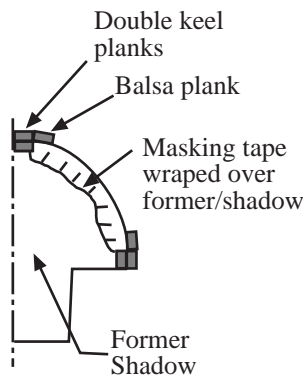

in the construction of the hull. The keel plank and deck rails are 1/8" th. X 1/4" wide strips of pine or basswood. The hull is planked with contest grade "lite" density balsa wood strips. Balsa comes in several densities. If you use hard density wood its not as easy to form the strips to the formers and the hull starts getting a little heavy. You can buy 1/8" th. X 3" wide X 48" long balsa sheets. Use a balsa stripper to cut the sheets into 5/16" wide strips for planking (you can't buy precut strips in this width and this is about the maximum width for easy planking). "Zap CA thin" glue can be used through out the construction of the hull. It will bond almost anything, including your fingers and sets up almost instantly. The joints must be tight, because the glue will not fill gaps.

Therefore if you have any gaps, fill them with Micro-Balloon filler or balsa dust, and then Zap it.

Ok lets start planking the hull. Lay in the first 1/4" wide pine keel plank and glue to each former. Glue a second pine plank on top of the first plank. Do this by pressing a few inches of the second plank tightly against the first plank and apply Zap to the edge where the planks meet. Capillary action will suck the glue between the planks. Continue this for the full length of the planks. For added strength in the keel fin area, glue a short 1/4" wide pine plank against both sides of the keel planking between formers 4 and 7. Install the deck rails on both sides with double planks of pine in the same manner as the keel planks.

Start the balsa planking at the deck rail, making sure the plank is tight against the deck rail edge. Zap the edge joint as you move along the length of the hull.

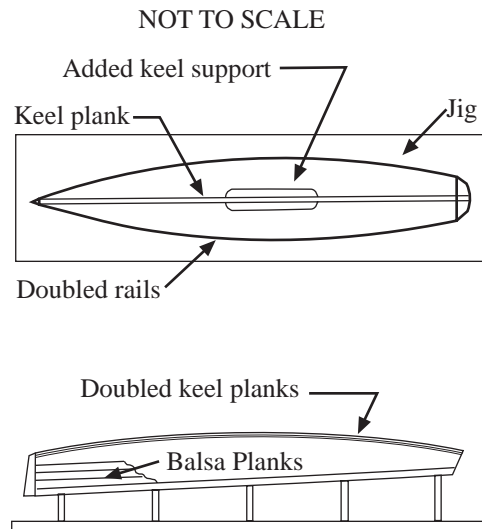

Continue laying planks making sure the edges are tight and that they follow the curve of the hull and are against the formers. Lay in about four planks on one side and then switch to the other side. Continue to plank the sides until you get near the water line at the bow. Glue a balsa plank along the hull bottom against the pine keel plank. Do both sides of the keel this way. For the remainder of the planking, trial fit each plank for length and end shape before gluing. When you lay flat planking strips against the curved area of the formers, the gluing edges don't meet squarely and you get a slight gapping of the edges. To

eliminate this, use a sanding block to put a slight angle on the edge of the plank to be glued in. It doesn't take much, just a swipe or two with the sanding block down the edge of the plank.

When the planking is completed, trim and sand flush any planking extending past the bow and stern formers.

Ok its time to sand the hull. Use a sanding block with 100 grit Garnet paper. Its important to use sharp (new) sandpaper. As soon as it starts getting dull change it.

Don't press hard on the sanding block, because it will cause low spots in the hull. The glue line between each plank is harder than the balsa wood, to prevent ridging of the glue line, sand diagonally across the planking. Rub your hand over the hull, and you can feel the bad spots easier than you can see them. When the hull feels and looks good, finish up with a light free-hand (no sanding block) sanding using 120 grit paper. Remember balsa wood sands fast and easy and the planking is only 1/8" thick.

Install the keel, ruder log and rudder, deck beams and hatch cover. These items are covered in other sections of the construction guide.

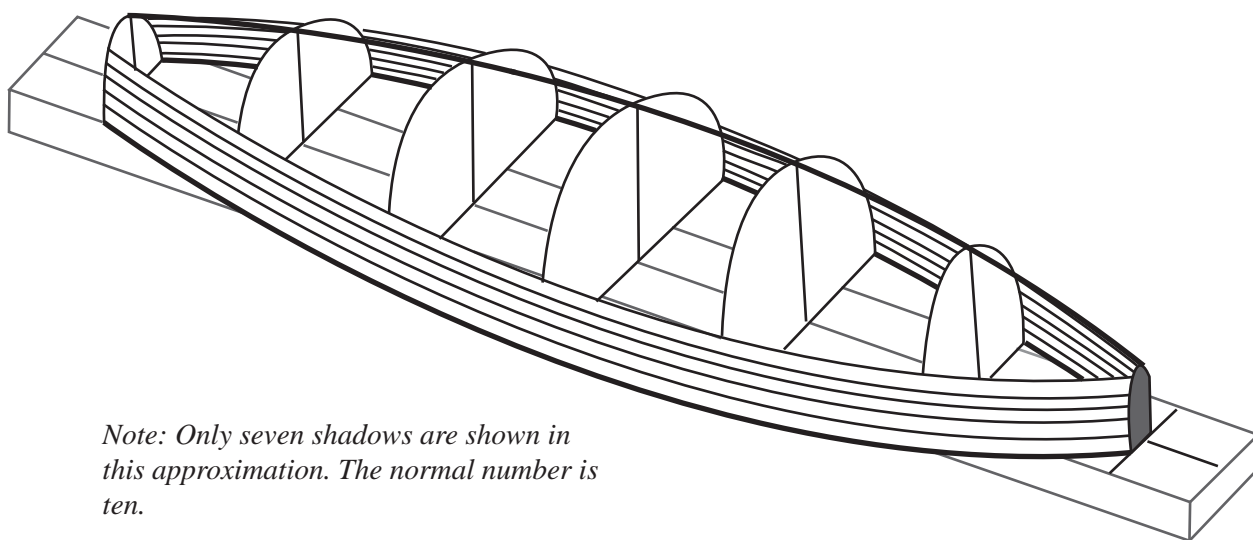

Note: Only seven shadows are shown in this approximation. The normal number is ten.

TRANSOM

Here's an easy way to make an attractive transom on your new hull.

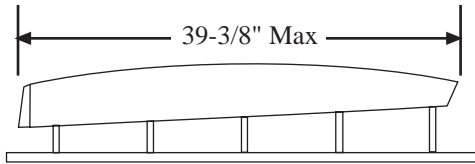

When the hull is planked, nose piece or bumper installed, hull sanded and **BEFORE** you remove the frames, place the hull on a flat surface. Measure the hull for over-all length. The maximum L.O.A. for a One Meter yacht is 39 3/8". Minimum is 39". This is measured parallel to the waterline.

Fit and glue a 1/8" thick plywood transom brace between sheer clamps.

Apply masking tape to give proper cut line. Use the

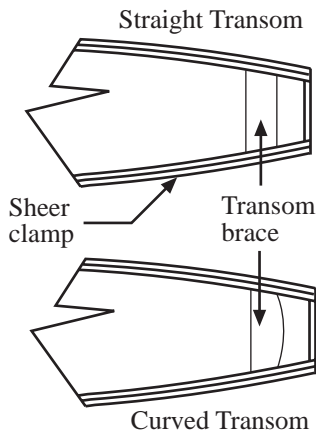

edge of the tape as a guide and cut through the clamps, planking and keel. Discard the last frame.

Use a sanding block to true and bevel edges. Glue a small sheet of 1/16" plywood across the open end of

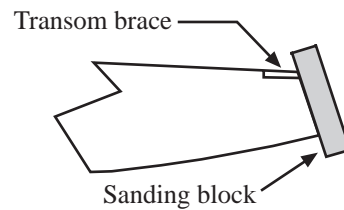
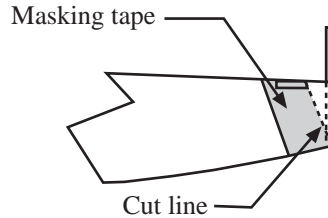

the hull. Trim and sand to final shape.

BE SURE OVERALL LENGTH DOES NOT EXCEED 39 3/8".

LAYING FIBERGLASS CLOTH ON YOUR HULL

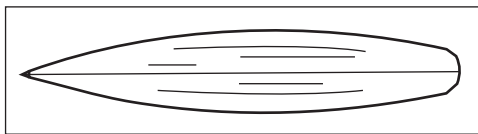

Sand hull smooth with 100 grit sandpaper. Fill in all gaps in planking and any low spots. Finish sand with 120 grit sandpaper.

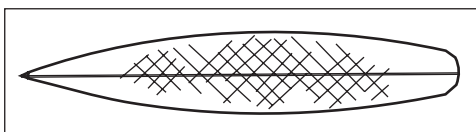

Place 1 oz. fiberglass cloth over dry hull, with fibers running approximately 45° to keel. Smooth out fiberglass cloth with palm of your hand over entire hull (except transom).

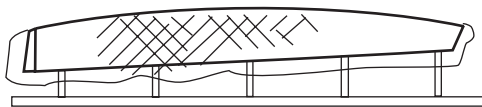

Trim fiberglass cloth approximately 1" from edges of hull.

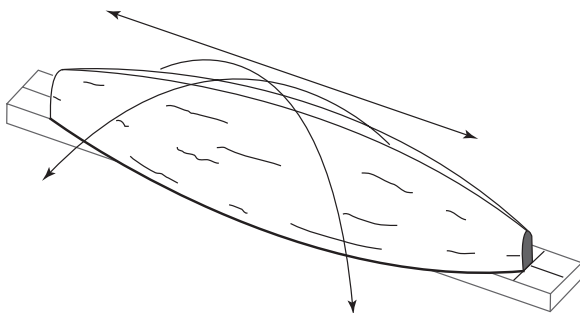

Gently apply resin or epoxy to the hull, starting in center of keel and work toward bow and stern. Apply resin or epoxy to the remainder of the hull using a downward motion and let cure.

Note:

If you are working with epoxy, thin approximately 30% with Isopropyl Alcohol to allow an even flow.

Trim all excess fiberglass from the hull, using a sharp knife or single edge razor blade. Trimming is easiest if resin is "green" (not completely cured).

When resin is dry, sand the hull with 225 grit "wet or dry" sandpaper to remove curtains and runs. If you used epoxy you will notice a feeling of oil on the un-sanded surface. This can be wiped off with alcohol or acetone and then sanded.

Note:

If you use polyester resin;

Use laminating resin for the 1st coat.

Use sanding resin for the 2nd coat.

Use finishing resin for the 3rd or last coat.

Your hull can be finished with a thin coat of high grade spar varnish or clear two-part epoxy paint.

FIN AND RUDDER JIG

The jig holds the fin or rudder in good alignment while the glue cures, and helps produce a straight fin or rudder. You can change the size of the jig to suit your needs. It's best to glue and/or screw the clamp bar pieces together (both upper and lower) before assembling the corner uprights to them. You can vary the air foil thickness of the fin or rudder by putting more or less angle in the clamp bar. More angle increases air foil thickness.

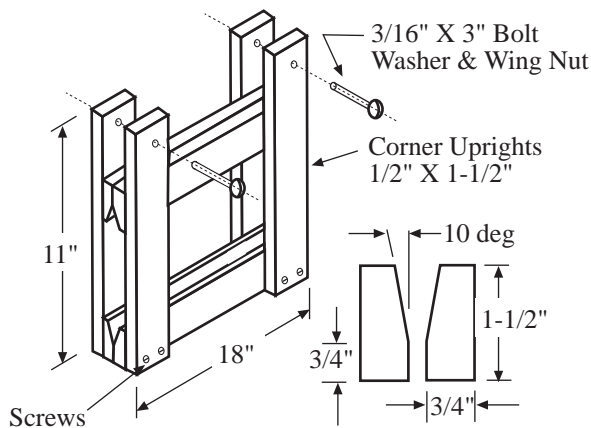

Fin or rudder skin materials can be, plywood, epoxy sheet, plastic sheet, Formica or similar material.

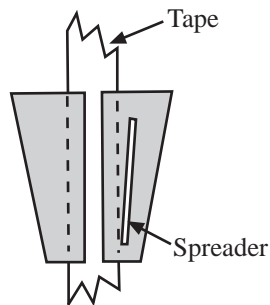

How To Use The Jig

- Place masking tape (sticky side up) on flat surface.
- Place fin sides on tape (inside up). Leave 1/16" gap between leading edges. It helps in the final shaping to taper material thickness on the inside edges of both the leading and trailing edges.
- Epoxy tapered spreader in place. The thickest end at top, the thickness depends on your airfoil thickness. The spreader is not needed in rudders.
- Put a sheet of plastic wrap or waxpaper in the groove of the lower block, to prevent glue from sticking to the block.
- Apply liberal amounts of epoxy to leading edge and spreader. Fold fin halves, pinch tape ends together. Place in lower grooved block of jig.
- Lower upper grooved block to make contact with fin, you may have to angle the block to match the angle of the fin. Tighten the wing nuts slightly to hold everything in place.
- Remove fin from jig when epoxy has set.
- Apply epoxy to inside surface of trailing edge. Pinch the edges together and place in lower grooved block. Lower the upper grooved block to clamp everything in place. Don't forget the plastic wrap!
- Remove fin after the epoxy has set.

KEELS

Keels can be either of the bolt-on type or the trunk type. They can be made from the following materials:

- Formica outer skin
- Aircraft plywood outer skin
- Solid shaped marine plywood
- Solid shaped aluminum stock
- Molded carbon fiber

The lightest, strongest, and most expensive keels are made from molded carbon fiber, available from some model boat vendors.

Aluminum fins are strong but heavy relative to fins made from carbon fiber or "skins".

Keels made from skins of Formica or aircraft plywood are the easiest to make with the use of a fin jig. They require a stiff spar material in the center of the fin. They're usually the least expensive.

Fins that insert into a trunk within the hull have less bend at the interface between the hull and the keel than keels that bolt to the bottom of the hull.

The following pages show alternate methods of making and mounting keels, and mounting bulbs to keel the fin.

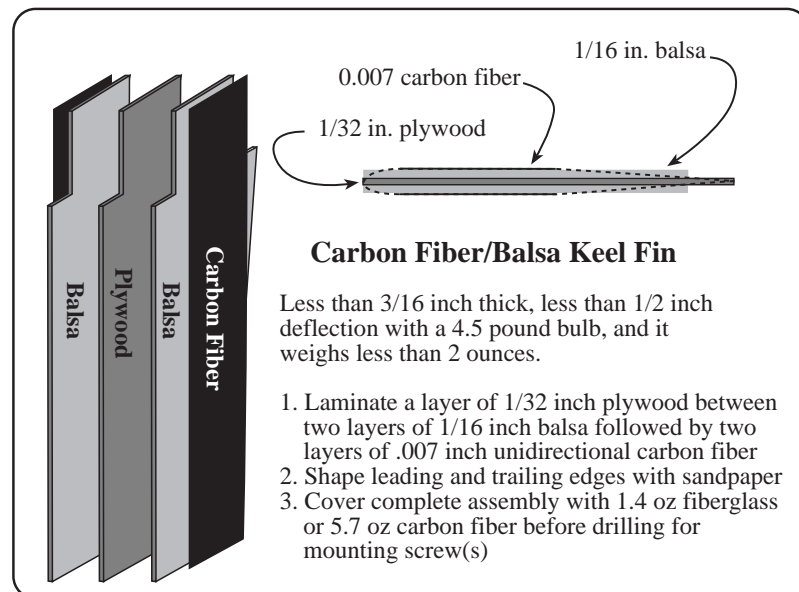

HULL REINFORCEMENT FOR BOLT-ON KEEL

Lay in fiberglass cloth the width of the top of the keel plus 1" fore and aft, from clamp to clamp. Allow resin to completely cure.

Cut and install 4 pieces of 1/32" plywood and sand both sides. Glue to fiberglass cloth with slow cure epoxy (with filler) and weight down to follow hull contour. Grain of wood should run fore and aft for ease of bending.

Install keel plate on keel, 1/16" sheet Formica (or any hard material) with slow cure epoxy. The plate keeps the keel bolts from deforming the wood keel plank.

Drill bolt holes to match your keel.

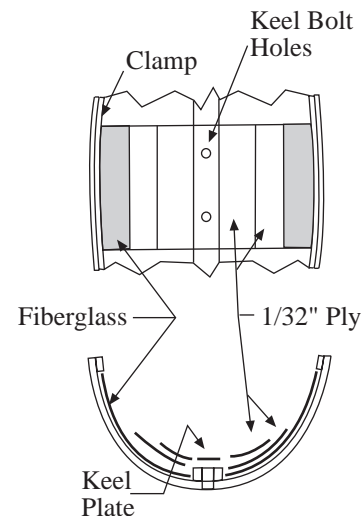

MOUNTING A BOLT-ON KEEL

Locate and drill holes in bottom of hull to accept keel bolts. Waterproof holes.

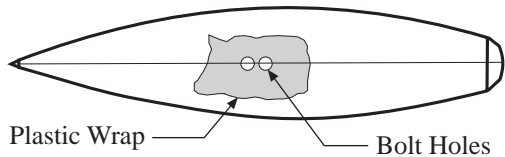

Cover bottom of hull around bolt holes with thin plastic wrap. Tape the wrap to hull. Punch holes in plastic wrap for keel bolts.

Support yacht hull in stand and measure from waterline to work bench at bow and stern. Dimensions A and B should be equal.

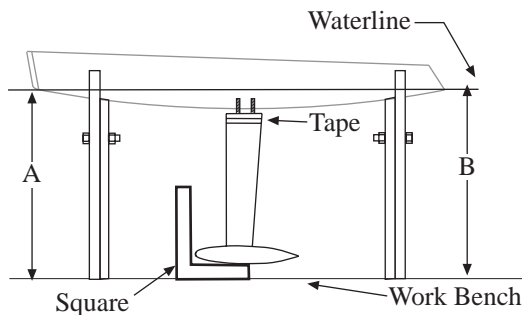

Place masking tape around upper portion of keel fin approximately 1/2" from top. Apply thin layer of slow cure epoxy with a filler (micro-balloons) additive to top outside surface of keel fin. CAUTION: Be sure the epoxy is not close enough to bolts to be forced up into bolt holes when mounting keel.

Press keel up into the hull until the epoxy starts to touch. Place nuts on bolts inside hull and gently hold bottom of keel. Screw the nuts down on keel bolts until enough epoxy shows on the sides of keel to create a fillet.

Use a square and line up the leading edge of keel fin to square. If your fin trailing edge is the one that should be perpendicular to the waterline, use this edge to line up with the square. Use keel nuts to adjust for squareness of the keel. Sight from the transom to ensure keel is vertically straight. Gently smooth down the fillet with finger or round edge of stick.

Let epoxy cure for 24 hours.

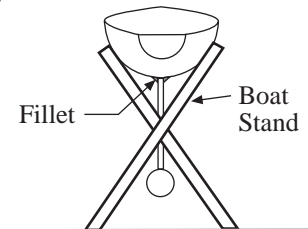

Remove keel, tape and plastic wrap from hull. Sand and paint as required.

When attaching the completed keel to the hull, be

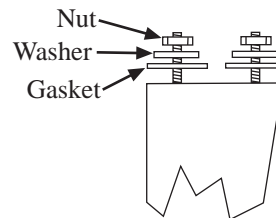

sure to use gaskets, washers and nuts in that order. To prevent water from entering hull through mounting holes. Gaskets can be made from neoprene faucet washers, bicycle inner tube material, etc..

FULL HEIGHT FIN TRUNK

The full height fin trunk serves a dual purpose, it secures the fin to the hull and acts as a mast support.

The trunk fits between the king plank and inner keel. The trunk sides and fin tongue are made from Birch 4 ply aircraft plywood. Make the fin tongue and stub from one piece of plywood. The trunk must be a good snug fit on the fin tongue.

Locate and cut a slot through both the inner and outer keel planks. Glue the trunk in the hull with epoxy or micro-balloons and Zap. Build a fillet around the joints. These joints bear heavy stresses and must be absolutely water tight.

Insert the fin tongue through the slot in the keel, push up until shoulder is snug against hull bottom.

A small bolt and wing nut holds the fin in place.

Waterproof fin, and trunk both inside and out.

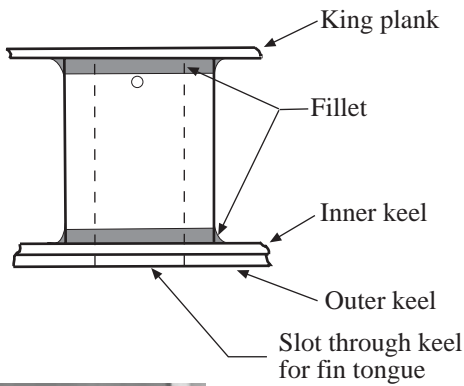

Trunk

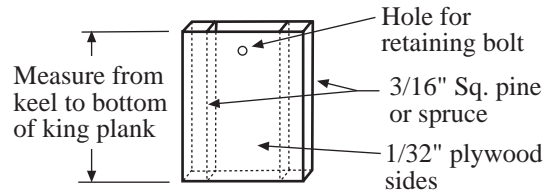

Fin Tongue

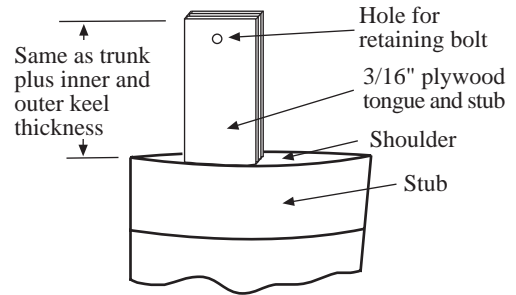

Not To Scale



Hal Robinson's Combination Mast Step and Keel Fin Trunk

The beauty of this unit is its simplicity and the fact that it automatically assures proper mast and fin alignment.

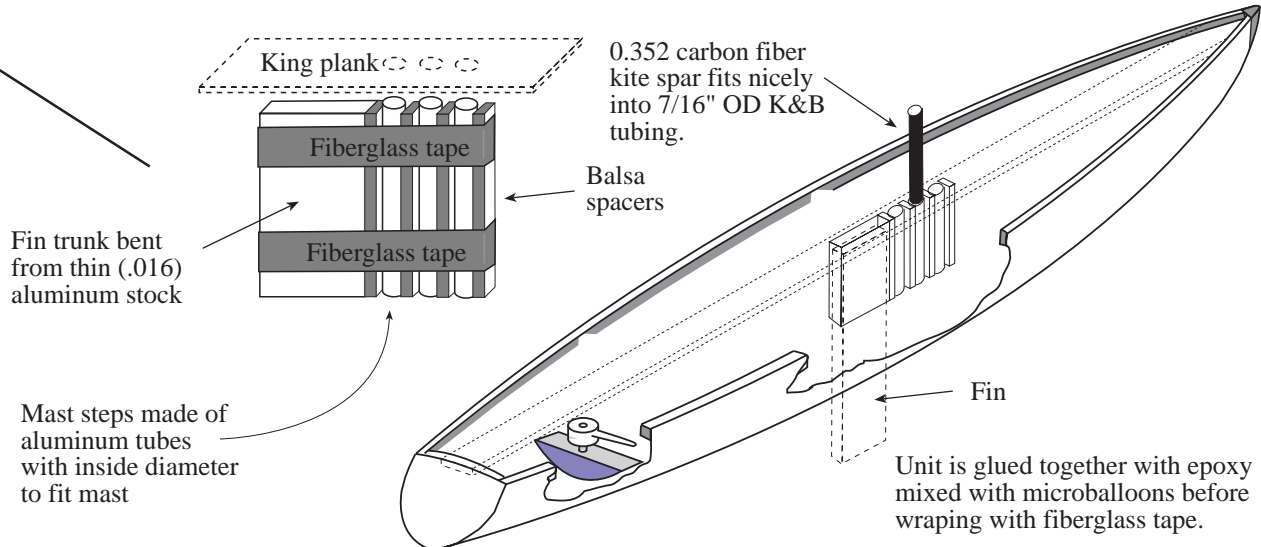

TRUNK TYPE FIN WITH ALUMINUM TUBE

This type fin has a trunk for mounting to the hull, and is removable from the hull. The fin is built up of 1/32" skin material and spruce stringers and aluminum tube for strength. The finished weight of the fin is 3.5 ounces.

Skin material is 1/32" thick aircraft plywood or "Vertical" Formica.

The aluminum tubing is 0.25" O.D. heat treated to the T-6 hard condition. Tube wall thickness is 0.060", this will make I.D. suitable for 8-32 tapping.

There are two spruce stringers, one forward and one aft of the aluminum tube.

File or grind 1/32" off opposite sides of the aluminum tube for the full length of the tube; they need to be flush with the stringers so the flat sides of the tube lay against the insides of the skins.

Cross-cut the aluminum tube to a depth of 1/16" every 5/8" along the two flat sides, so the tube will "lock" in place when epoxied to the skins.

The top and bottom of the fin is filled with a filler of micro-balloons and epoxy or resin.

Tap 8-32 thread 1" deep on each end of the aluminum tube. For holding the fin in the hull and mounting the bulb to the fin.

Be sure to put a good water proof finish on the fin.

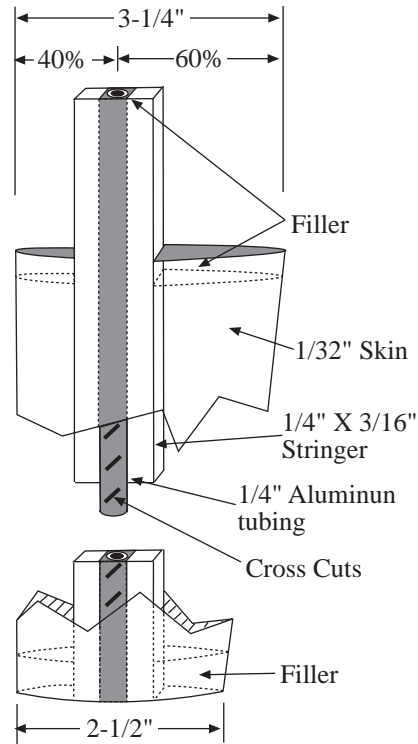

Top View

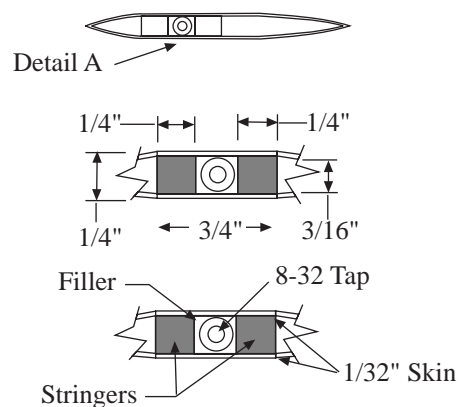

Detail A

Not To Scale

SHORT FIN TRUNK

A short fin trunk will allow an arm type Sail Control Unit (SCU) to swing through an obstructed

The 8-32 stainless screw (with the head cut off) is used as a stud, screwed into the top of the fin. Secure fin in trunk with washer and hex or wing nut placed on stud.

The fin should be a snug fit in the trunk.

Make a strong water tight fillet at the junction of the trunk and hull bottom, use epoxy and 1/2 oz fiberglass or micro-balloons and Zap.

The groove between the aft thwarts can be used for radioboard mounting.

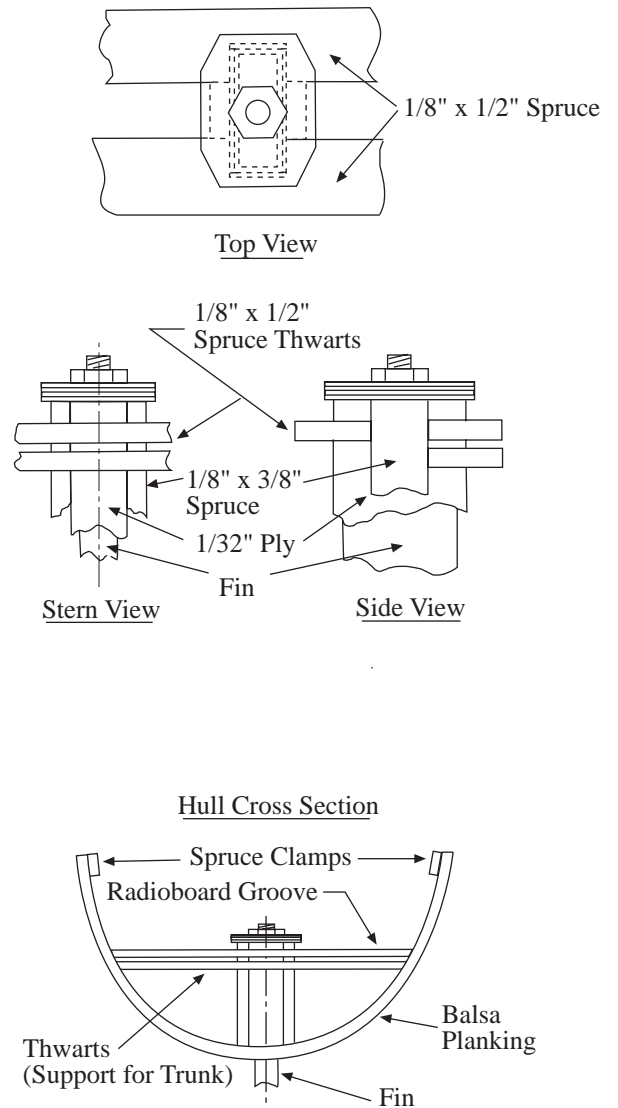
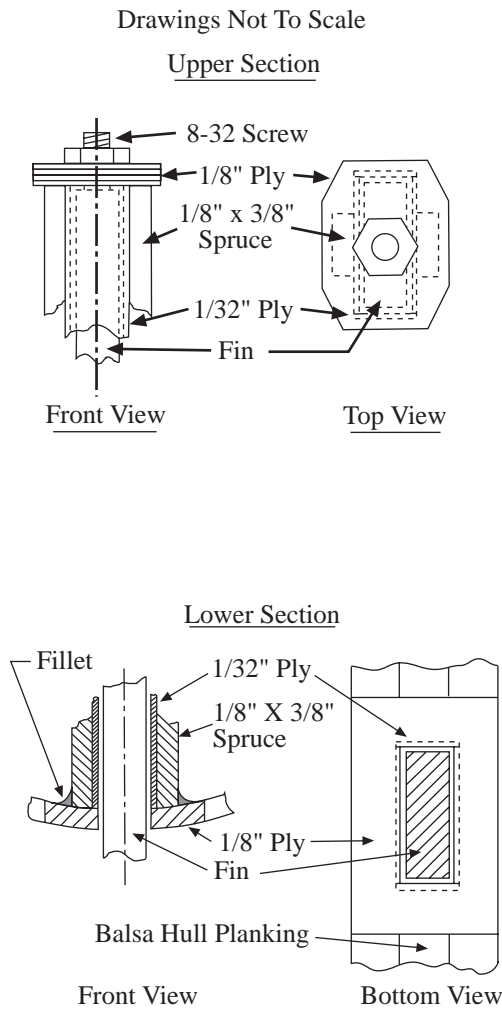

ATTACHING BULB TO FIN WITH ALUMINUM TUBE

Mounting the bulb to fin with a screw allows you to easily change the bulb, so you can experiment with different bulb weights.

Be careful when drilling the clearance hole for the 8-32 machine screw through the lead bulb, the lead wants to grab onto the drill bit. To help prevent this, use lots of cutting oil and frequently clean the lead from the drill bit.

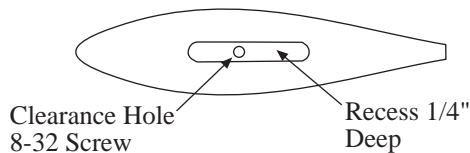

You can make the 1/4" deep recess in the bulb with a moto-tool or rotary bit in a drill motor.

Tap the bottom of the fin with the 8-32 tap about 1/2" deep.

If you want the bulb removable from the fin, smear a little heavy grease on the bottom of the fin and up the sides about 1/2". This keeps the resin from adhering to the fin.

Attach the bulb to the fin with the screw. Make sure it's aligned straight fore and aft with the fin, and the forward tip of the bulb is about 1/8" higher than the aft end of the bulb.

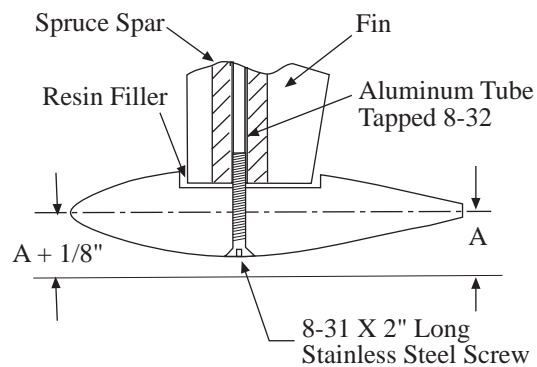

Fill the cavity around the fin with a filler of resin and micro-balloons. Allow to cure for 24 hrs.

Clean off excess grease from fin and sand resin filler smooth. That's it...

ATTACHING BULB TO FIN

Drill two pilot holes in lead bulb at an angle, to a depth of 1/2". Drive nails into angled pilot holes and flatten nail heads. Leaving approximately 3/4" of nail exposed.

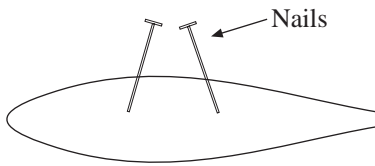

Slip keel blade down over nails. Some sanding will be required to fit the bottom of blade to top of lead bulb. the forward point of bulb should be elevated approximately 1/8" above aft end of bulb.

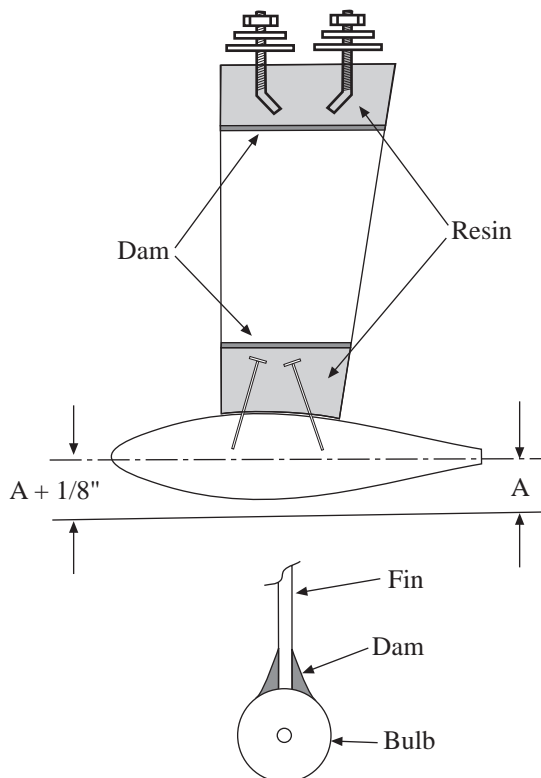

Using filler material (auto body surfacing putty), make a dam around base of blade and top of bulb. Pour approximately 1/2 oz. of epoxy or resin into top of keel blade to cover top of nails. Let epoxy or resin cure.

Make a dam at top of fin by cutting and shaping scrap balsa to fit into top of blade approximately 2" from top.

Cut and bend two 2" long 10-24 stainless steel machine screws and flatten heads. Place bolts approximately 1 1/2" into cavity. Use large nuts and washers to suspend bolts above top of keel. The amount of bolt above the keel is determined by the thickness of the keel mounting block in the hull.

Pour epoxy or resin into cavity and let cure.

Sand and paint finished keel as desired.

LEAD BULB CASTING

We will explain two methods for casting a keel weight bulb. The 1st is lead shot and resin method, the 2nd is cast lead method. Both methods require a bulb pattern for making a mold.

Bulb Pattern

Fig 1. Tack (lightly) glue two blocks of 1"X 2"X 10"

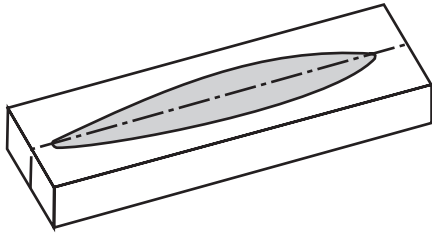

(this will vary with bulb size) balsa wood together. A layer of thin cardboard lightly glued between the blocks makes splitting them apart much easier. The glue joint will be broken apart later.

Trace bulb outline on top of blocks. Whittle, carve and sand to this outline and finish to a torpedo shape. The bulb must be symmetrical in shape. The bulb can be turned on a lathe or electric drill motor. A coarse sandpaper block will take the block down to shape. When finished shaping, split the block apart along the glue seam.

Lead Shot and Resin Method

Fig. 2. Glue the pattern halves to a small panel of hardboard or plywood. Place 1 1/2" high sides around edge of panel. Use masking tape to hold box together and make it watertight.

Wax (floor, auto, any paste wax) all interior surfaces of box including bulb halves.

Mix a slurry of casting plaster and water. Make it like heavy cream. Pour slurry into box completely covering bulb halves. Fill to top of sides.

Fig. 3. When plaster has set, remove sides and bottom panel. You have a block of plaster with two concave recesses.

Let the plaster dry. This may take days, however, you

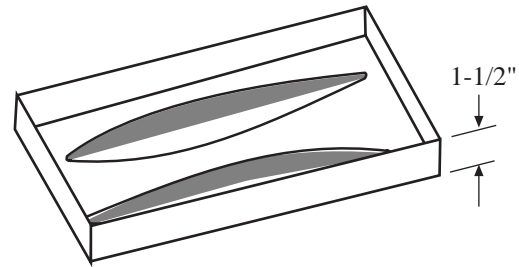

can speed up the process by using your kitchen oven. Three or four hours at 200 degrees F, maybe longer, should do the trick. Let plaster cool. Place plastic wrap (Saran, etc.) over plaster mold. This acts as a parting agent and allows the slugs to be removed from the mold easily.

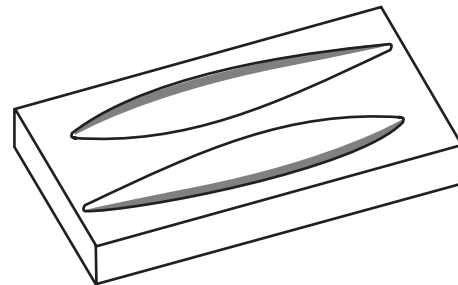

Fill recesses with lead shot (the smaller, the better) and tamp lightly. Thin a quantity of resin (casting resin is best) with acetone. Be sure to catalyze. Pour the resin into the lead shot in both halves.

After the resin has cured, the bulb halves should pop out of the mold easily. Remove plastic wrap. If resin is tacky allow to set completely.

Use a file or sandpaper block to “true” the flat inner surfaces. Epoxy the two halves together. Hold in place with masking tape until epoxy has set and cured. Remove tape. There’s your bulb !

Poured Lead Method

Use the torpedo shaped bulb pattern to make your plaster mold. The intense heat of molten lead might shatter a double mold (as is shown for the shot and resin method) so we will make two individual molds. You only need one but it’s good to have some “insurance”.

Fig. 4. Follow the instructions for the Lead Shot and Resin Method for construction, waxing and pouring of the casting plaster, for both molds.

DANGER

The plaster molds must be absolutely dry before pouring lead. When molten lead is poured into the mold, the intense heat turns any moisture in the plaster into steam, which can explode the mold and splatter mol-

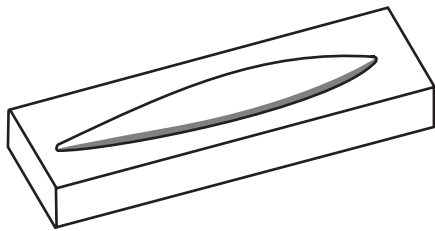

ten lead everywhere.

You can help the drying process by placing the molds in your kitchen oven for four hours at 200 degrees F.

Lead can be melted in an old frying pan. If you have an old cast iron frying pan (small), especially one with a spout, your in business. Your kitchen range or an electric hot plate will do for heat.

The lead should be clean, dry and in relatively small pieces. Start with a few pieces and when they start to melt, add more and the rest will melt rapidly. Impurities will rise to the top. Skim them off with an old spoon. The molten lead is ready to pour when a small wooden stick chars lightly when pressed into it.

Try to work out of doors during the melting and pouring process. Be careful when working with the molten lead.

Pour lead smoothly into the mold. Lead should be right up to the top of the mold. Pour the second bulb half.

Let bulb halves cool, they retain heat for a long time. Be careful.

Pop halves out of mold. “True” flat inner surfaces with a file, epoxy halves together. Hold together with masking tape until epoxy has cured.

You may want to drill and countersink two holes through the bulb, for bolts and nuts. There’s your lead bulb!

KEEL BULB SHAPE

By Dave Acree, Mesa MYC

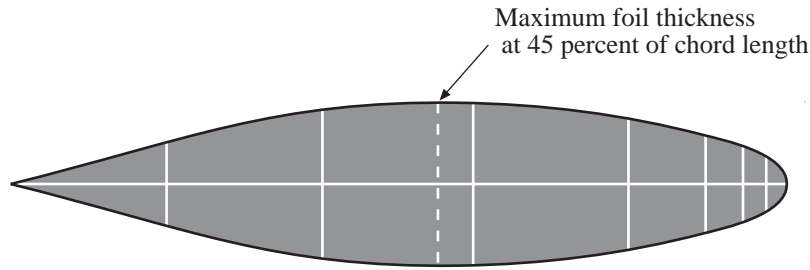

Torpedo shaped keel bulbs do not provide lift, they simply help keep the boat upright. The goal in designing a keel bulb is to minimize drag. According to the U.S. National Advisory Committee for Aeronautics (NACA), if a bulb's volume of weight is constant, the size and length does make a difference. A long bulb with a small diameter produces a large wetted surface and high frictional drag, but is low in form drag. A bulb that is short and fat produces a small wetted surface and low frictional drag, but high in form drag. Both of these extremes will not give the performance a model yachter wants. The best performance is produced by a trade-off between chord length and thickness. Ideally, the maximum foil thickness of the bulb should be at 45 percent of the chord length. Note in the graph below that the point of minimum drag is lowest between 2 and 2.5. Anything before or after the 2 to 2.5 range creates more drag.

Drag vs. keel bulb diameter (where bulb volume is constant).

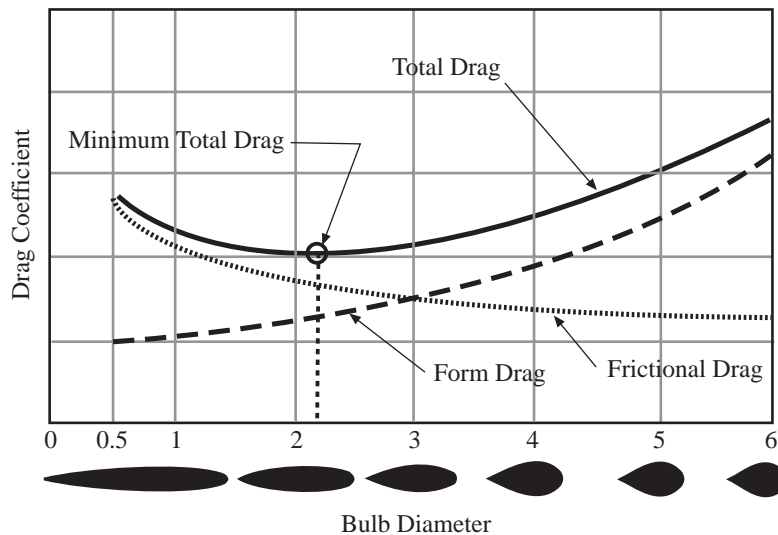

RUDDERS

There are several methods for fabricating rudders. The basic square "skin" method. For rudders with curved shape, use shaped solid balsa wood covered with fiberglass and resin, or molded carbon fiber type. The installation of rudder to hull is the same for all types. The rudder should be placed as far aft as possible, without any part of the rudder extending past the hull. The method shown here is the "skin" type.

The "skin" type rudder is a light weight easy to construct rudder. The skin material can be 1/32" thick aircraft plywood, Formica, plastic sheet, or fiberglass resin lamination. The rudder shaft is 5/32" dia. rod either brass or hard aluminum.

Use the Fin and Rudder Jig, and instructions to build your basic shape.

Make the 5/32" dia. rudder shaft with a bend on one end. The bend prevents the rudder from turning on the shaft. You may have to file flats on the bent end, to allow it to slip into the rudder without bulging the sides.

Push cotton down inside the rudder to form a dam,

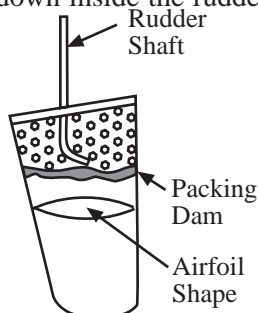

slightly below the rudder shaft. Align the shaft in the rudder so that it is at right angles to the water line of the hull, vertically straight with the rudder sides, also with about 60 % of the rudder area aft of the shaft. When it's in alignment tack glue it with Zap. Now you can fill the inside of the rudder with a filler of micro-balloons and resin or epoxy.

Zap or epoxy wooden end caps on the rudder and finish shape. The top cap can be used to get a good rudder/hull fit.

Finish off with a good water proof finish.

RUDDER LOG

The rudder log is a piece of 5/32" I.D. brass tubing located in the hull, that the rudder shaft slips into. The tubing must be long enough to extend through the keel, thwart (plywood brace), and above the waterline.

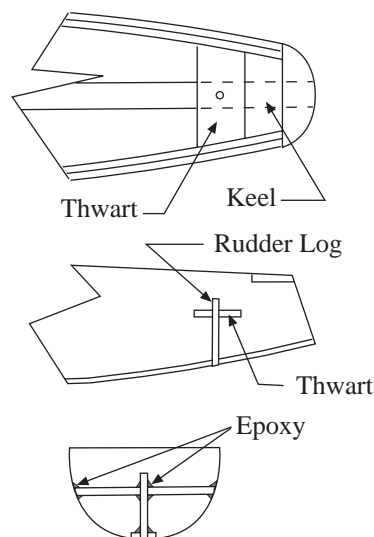

Locate the position of the rudder shaft. Drill a 3/16" hole through the keel and bottom of hull. This hole must be drilled at right angles to the waterline. Insert the correct length of 5/32" I.D. brass tubing through the hole, through the thwart extending above the waterline. Be sure

the rudder log is vertical and at right angles to the waterline. Tack glue with Zap, check alignment. Alignment is easier if you insert a long length of 5/32" music wire, rod or tubing in the rudder log while "eye balling" the alignment. Glue it all with micro-balloons and Zap or epoxy.